

Design and development of an inverter for floating solar panels

^a Engr. Areeba, Engr. Zain ul Abdin, Engr. Ali Muhammad, Ghulam Taha

^a Mehran University of Engineering and Technology

Corresponding author e-mail: (areebadakh@gmail.com)

[Received on: 04-11-2025 Accepted on: 06-01-2026 Published on: 06-01-2026]

Abstract — The growing global demand for renewable energy and the scarcity of land for large-scale solar installations have accelerated the development of Floating Photovoltaic (FPV) systems. To ensure efficient DC–AC conversion and high power quality in such systems, in this paper, the Phase Disposition (PD) Pulse Width Modulation approach in MATLAB/Simulink is used to develop and simulate an 11-level Multilevel Inverter (MLI). The proposed inverter efficiently converts the DC output from floating solar panels into an enhanced AC waveform with a notably lower Total Harmonic Distortion (THD). The modular structure of the inverter enhances scalability, reliability, and system efficiency while minimizing switching losses and filter requirements. Simulation results verify that the 11-level PD-based MLI provides smooth voltage output, improved waveform quality, and reduced harmonics, making it a viable option for applications involving FPV and other renewable energy sources.

Index Terms — Floating Photovoltaic (FPV); 11-Level Multilevel Inverter (MLI); Cascaded H-Bridge Multilevel Inverter (MLI); Phase Disposition (PD); MATLAB/Simulink; DC–AC Conversion.

I. INTRODUCTION

In recent years, advancements in renewable energy have played a crucial part in the fight against climate change and addressing the increasing global demand for electricity. Solar power is the most promising renewable energy source for addressing these urgent issues. Floating photovoltaic (FPV) systems, an innovative alternative to conventional solar farms, are installed on water surfaces. This approach not only conserves valuable land resources but also reduces water evaporation and enhances energy efficiency through natural cooling [1] - [2]. By maximizing energy generation and promoting environmental sustainability, FPV systems present a compelling strategy to meet today’s energy needs. The technique utilized to transform the direct current (DC) generated by solar panels into alternating current (AC), which is appropriate for direct consumption or grid integration, has a major impact on the efficiency of FPV systems. This critical function is performed by an inverter, a core component of any solar power system. The inverter ensures that the generated power meets the required quality and reliability standards for practical applications. In the case of FPV installations, this task becomes even more crucial due to the unique operational

and environmental challenges associated with water-based systems [3]. While conventional inverters are effective in many solar applications, they often fall short of meeting the specific requirements of FPV systems. Challenges such as the need for higher efficiency, the reduction of harmonic distortion, and the variability of DC input from multiple solar panels necessitate a more advanced inverter design [4]. Harmonic suppression is particularly important, as excessive total harmonic distortion (THD) can degrade power quality and violate grid interconnection standards [5].

II. METHODOLOGY

A. Block Diagram of Cascaded H-Bridge Multilevel Inverter

Figure 1 displays the block diagram of the Cascaded H-Bridge 11-level multilevel inverter. There are a total of five H-Bridges, each bridge is supplied with 4.8v through the floating PV output (24v). The circuit comprises of 20 IGBT switches.

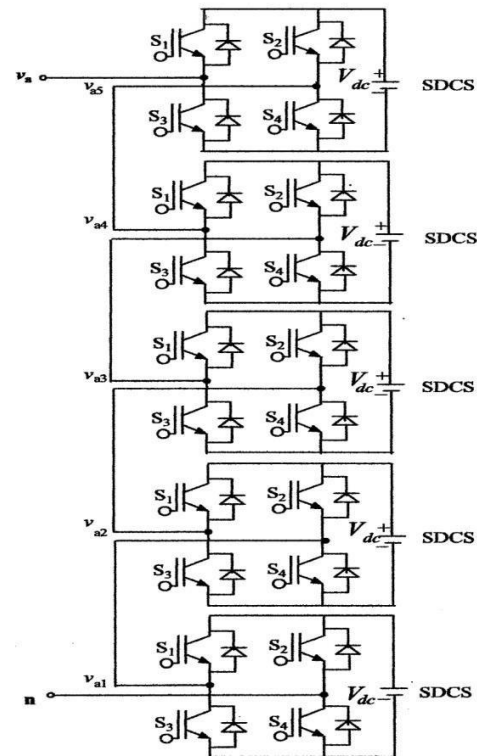

Figure 01: Cascaded H-Bridge Multilevel Inverter

The following formulas are used to calculate the various parameters of the suggested 11-level Cascaded H-Bridge (CHB) Multilevel Inverter:

Equation (1) provides the inverter's total output voltage.

$$V_{out} = \sum_{n=1}^K V_n = V_1 + V_2 + V_3 + V_4 + V_5 \quad (1)$$

Equation (2) provides the number of effective output voltage levels.

$$N_L = 2K + 1 \quad (2)$$

The number of power switches required is given in eq. (3)

$$N_{SW} = 4K \quad (3)$$

The number of PV modules or strings serving as input sources is given in eq. (4)

$$N_{PV} = K \quad (4)$$

Where,

- N_L = Number of output voltage levels
- N_{SW} = Number of switching devices
- N_{PV} = Number of PV modules/strings
- K = Number of H-bridge cells

B. Switching Scheme

The operational states of semiconductor switches in a Multilevel Inverter (MLI) are specified by a switching table in order to attain the necessary output voltage levels. Regarding the suggested 11-level Cascaded H-Bridge (CHB) inverter, each H-bridge cell operates with a specific combination of switches to generate stepped voltage levels ranging from +5V to -5V. The Phase Disposition (PD) PWM technique determines the switching sequence by comparing a sinusoidal reference waveform with ten in-phase carrier signals. Table I displays the inverter's switching states for each level. In positive levels (+1V to +5V), the upper switches of each H-bridge conduct sequentially to build up the output voltage, while in the negative levels (-1V to -5V), the lower switches conduct in reverse order to generate the corresponding negative voltage. The zero state (0V) occurs when the positive and negative H-bridge outputs balance each other.

TABLE I: Switching Scheme for 11-Level CHB MLI

State	S1	S2	S3	S4	S5	S6	S7	S8	S9	S10	S11	S12	S13	S14	S15	S16	S17	S18	S19	S20	Level
1	1	0	0	1	1	0	1	0	1	0	1	0	1	0	1	0	1	0	1	0	+1
2	1	0	0	1	1	0	0	1	1	0	1	0	1	0	1	0	1	0	1	0	+2
3	1	0	0	1	1	0	0	1	1	0	0	1	1	0	1	0	1	0	1	0	+3
4	1	0	0	1	1	0	0	1	1	0	0	1	1	0	0	1	1	0	1	0	+4
5	1	0	0	1	1	0	0	1	1	0	0	1	1	0	0	1	1	0	0	1	+5
6	1	0	1	0	1	0	1	0	1	0	1	0	1	0	1	0	1	0	1	0	0
7	0	1	1	0	1	0	1	0	1	0	1	0	1	0	1	0	1	0	1	0	-1
8	0	1	1	0	0	1	1	0	1	0	1	0	1	0	1	0	1	0	1	0	-2
9	0	1	1	0	0	1	1	0	0	1	1	0	1	0	1	0	1	0	1	0	-3
10	0	1	1	0	0	1	1	0	0	1	1	0	0	1	1	0	1	0	1	0	-4
11	0	1	1	0	0	1	1	0	0	1	1	0	0	1	1	0	0	1	1	0	-5

C. Switching Modes

Each switching mode defines a unique combination of semiconductor switches (IGBTs) that determine the inverter's output voltage level. In this topology, the desired stepped waveform is produced by connecting several H-bridge cells in series, each of which is powered by a separate PV source. By properly controlling the ON and OFF states of the switches according to the PD technique, the inverter produces output voltage levels ranging from +5V to -5V. For the floating solar PV system, each switching mode corresponds to one of these voltage levels, guaranteeing seamless level transitions, lower harmonic distortion (THD), and improved power quality.

III. SYSTEM DESIGN

A. Simulation Model of Solar PV with Boost Converter

Figure 2 shows the simulation model of the proposed system. The setup is based on photovoltaic (PV) sources as the input power supply. In order to provide a steady DC link voltage for the inverter, the system uses a boost converter to increase the PV voltage from 24 V input to 48 V output. The 11-level CHB inverter is then fed the increased DC voltage using the Phase Disposition (PD) PWM approach to provide a smooth AC output with less harmonic distortion.

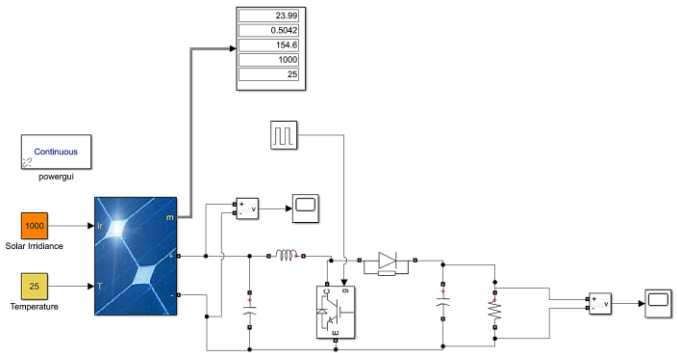

Figure 02: Simulation Model of Solar PV with Boost Converter

B. Simulation model of Proposed MLI System

In the proposed Cascaded H-Bridge (CHB) multilevel inverter for floating photovoltaic (FPV) applications, each subunit consists of four IGBT switches and a load resistor [6]. The IGBTs act as the main power switches that determine the voltage step generated by each H-bridge. The load resistor represents the connected load and stabilizes the system by balancing voltage levels, limiting inrush currents, and safely dissipating energy during transient operations [8]. Each H-bridge cell receives DC input from the PV source, which is boosted to the required level using a DC-DC boost converter [9]. Figure 3 illustrates how the subunits work in collaboration to produce several stepped voltage levels that are combined to create an 11-level output waveform.

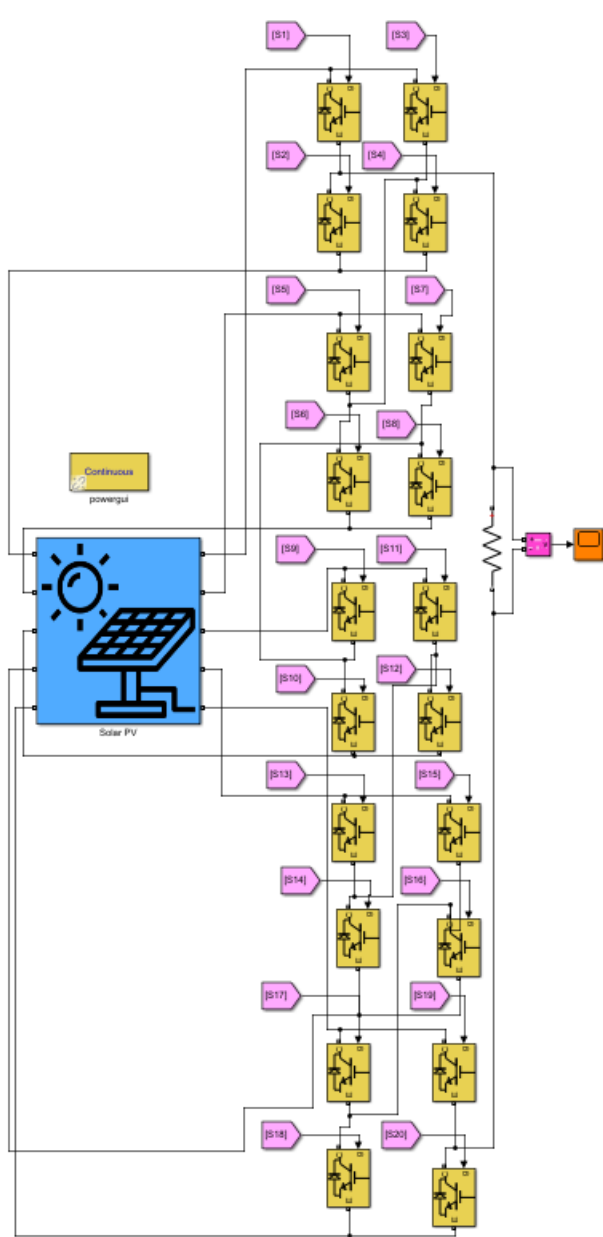

Figure 03: The proposed MLI system's simulation model

C. Simulation Model of Switching Circuit

Phase Disposition Pulse Width Modulation (PD-PWM) is used in the switching circuit of the suggested Cascaded H-Bridge (CHB) inverter to produce the gating signals for the IGBTs [7]. In this scheme, ten carrier signals are used, all of which are in phase with one another but vertically displaced along the amplitude axis. The switching instants for each IGBT pair are found by comparing these carriers with a single sinusoidal reference waveform, thereby controlling the inverter's output voltage levels [6]. The PD-PWM technique ensures symmetric operation of the inverter and produces an 11-level stepped AC output with smooth transitions between voltage levels, Figure 4 depicts the switching circuit simulation model.

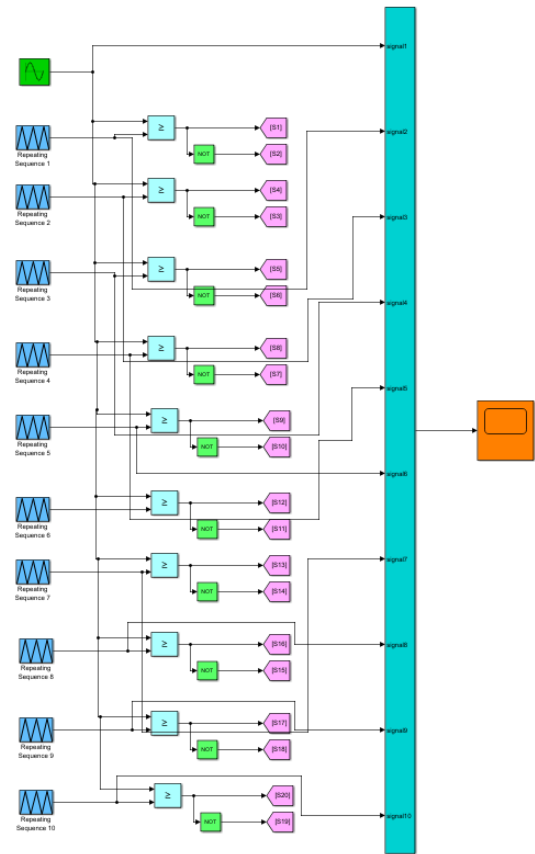

Figure 04: Simulation Model of Switching Circuit

IV. SIMULATION RESULTS

The performance of the suggested Cascaded H-Bridge (CHB) multilevel inverter used for floating photovoltaic (FPV) applications is depicted in the simulation waveforms below. The outcomes verify that the Phase Disposition Pulse Width Modulation (PD-PWM) method was successful in producing an 11-level stepped output voltage waveform. The switching function of the inverter's H-bridge subunits is represented by each output step, producing a waveform that closely approximates a sinusoidal output. The simulation demonstrates stable operation with proper voltage boosting from the PV source and effective phase disposition among carrier signals. These outcomes confirm that the inverter can produce high-quality AC output that can be included into renewable energy systems.

A. Output of Solar PV System

The main DC power source for the suggested inverter system is the photovoltaic (PV) array. The PV modules together produce a steady output voltage of 24 V under standard test conditions (STC) with an irradiation of 1000 W/m² and a cell temperature of 25°C. A DC-DC boost converter is then used to raise this voltage to 48 V, guaranteeing enough input for the 11-level Cascaded H-Bridge (CHB) multilevel inverter, as shown in Figure 5, which displays a smooth DC output appropriate for applications involving the conversion of renewable energy.

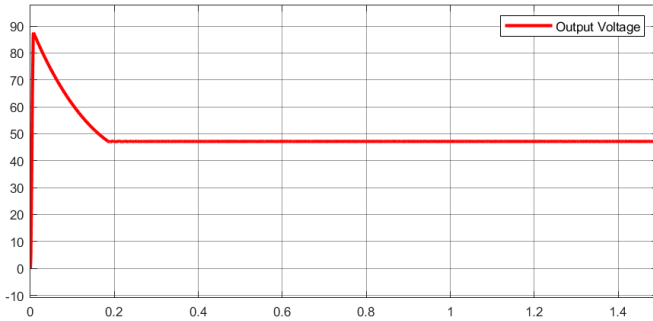

Figure 05: Output of Solar PV System

B. Multilevel Inverter's Output Voltage

The suggested Cascaded H-Bridge (CHB) multilevel inverter has an output voltage of 48 V and an output current of 0.48 A. The inverter is powered by photovoltaic (PV) sources, which are boosted from 24 V input to 48 V output through a DC–DC boost converter. The generated multilevel AC waveform demonstrates smooth and stable operation of the system under open-loop conditions. Figure 6 below displays the simulated output voltage and current waveforms.

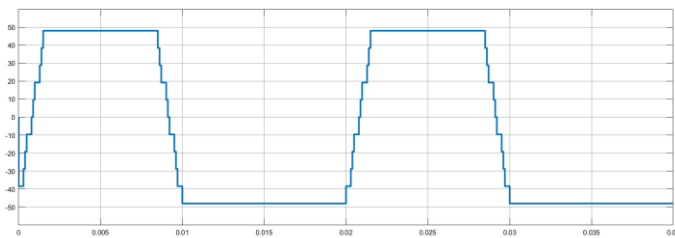

Figure 06: Output of 11 Levels Multilevel Inverter

V. CONCLUSION

This study designs and simulates an 11-level single-phase Cascaded H-Bridge (CHB) multilevel inverter (MLI) for floating photovoltaic (FPV) applications. The proposed topology utilizes photovoltaic (PV) sources as the primary input, which are boosted from 24 V to 48 V using a DC–DC boost converter. Phase Disposition Pulse Width Modulation (PD-PWM) is used by the inverter to perform switching, using 10 carrier signals to generate a smooth 11-level output waveform [10]. The simulation is run in MATLAB/Simulink under standard test conditions, with a temperature of 25°C and an irradiation of 1000 W/m². The obtained results show an output voltage of 48 V and a corresponding output current of 0.48 A, demonstrating stable inverter performance and effective voltage boosting. The proposed design requires fewer components compared to conventional topologies while maintaining high-quality AC output, making it a suitable and efficient choice for renewable and floating solar applications.

ACKNOWLEDGMENT

I am thankful to supervisor and co-supervisor who helped and motivated us during this research paper. They were cooperative and with a lot of advice encouraged me a lot in writing research paper. We also thankful for their effective guideline in this research.

REFERENCES

- [1] A. Sahu, N. Yadav, and K. Sudhakar, "Floating photovoltaic power plant: A review," *Renewable and Sustainable Energy Reviews*, vol. 66, pp. 815–824, 2016. [\[Elsevier\]](#)
- [2] Y. Liu, H. Sun, and Z. Zhao, "Floating PV system design and application: State-of-the-art," *Solar Energy*, vol. 228, pp. 454–472, 2021. [\[Elsevier\]](#)
- [3] D. C. Jordan and S. R. Kurtz, "Photovoltaic degradation rates — An analytical review," *Progress in Photovoltaics: Research and Applications*, vol. 21, no. 1, pp. 12–29, 2013. [\[IEEE\]](#)
- [4] M. A. Ghasemi, M. N. Bin M. Nasir, and H. Hizam, "Advanced inverter technologies for grid-connected photovoltaic systems: A review," *IEEE Access*, vol. 8, pp. 141–155, 2020. [\[Research Gate\]](#)
- [5] A. Kulkarni and V. John, "Mitigation of lower order harmonics in a grid-connected single-phase PV inverter," in *Proc. IEEE Energy Conversion Congress and Exposition (ECCE)*, 2012, pp. 5018–5025.
- [6] J. Rodriguez, J. S. Lai, and F. Z. Peng, "Multilevel inverters: A survey of topologies, controls, and applications," *IEEE Transactions on Industrial Electronics*, vol. 49, no. 4, pp. 724–738, 2002.
- [7] S. Kouro et al., "Recent advances and industrial applications of multilevel converters," *IEEE Transactions on Industrial Electronics*, vol. 57, no. 8, pp. 2553–2580, 2010.
- [8] H. Akagi, "Classification, terminology, and application of the modular multilevel cascade converter (MMCC)," *IEEE Transactions on Power Electronics*, vol. 26, no. 11, pp. 3119–3130, 2011.
- [9] M. A. Eltawil and Z. Zhao, "MPPT techniques for photovoltaic applications," *Renewable and Sustainable Energy Reviews*, vol. 25, pp. 793–813, 2013.
- [10] K. K. Gupta and S. Jain, "Comprehensive review of a recently proposed multilevel inverter," *IET Power Electronics*, vol. 7, no. 3, pp. 467–479, 2014.